

臥式專用交換台 Auto Pallet Changer

- ◆ 產品特性：高精度、高剛性、配合加工中心機、可作四軸同動加工；配合光學尺可達更高之定位精度。
- ◆ Characteristics: High accuracy and high rigidity. The 4th axis can be operated synchronously with machining center. Equipped with encoder to improve better position accuracy.

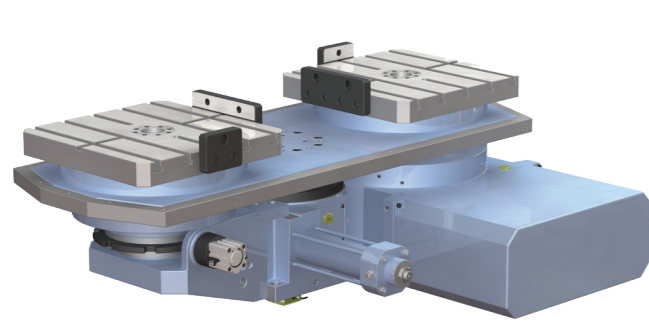

PRT-M4075

動柱臥式專用交換台
Auto Pallet Changer (Sliding column)
動柱臥式加工中心機專用
For Sliding Horizontal CNC Machining Center

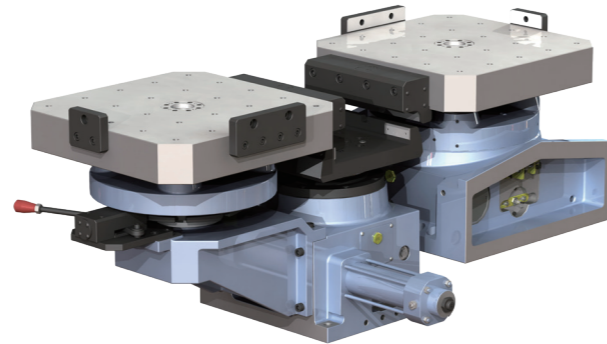

PRT-F5085

定柱臥式專用交換台
Auto Pallet Changer (Fixed column)
定柱臥式加工中心機專用
For Fixed Horizontal CNC Machining Center

型式 Model		PRT-M4075	PRT-F5085
工作台尺寸 Table(L x W)	mm	400 X 400	500 X 500
總高度 Overall height of machine	mm	420	420
基準中心孔 Nose diameter	mm	Ø 50	Ø 50
T 型槽寬度 Width of T-slot	mm	14 H7	18 H7
基準導槽寬 Width of Guide block	mm	18	18
最小分割角度 Min. indexing degree	degree	0.001°	0.001°
分割精度 Indexing accuracy	arc sec	15"	15"
重現精度 Repeatability	arc sec	±2"	±2"
剎車扭力 Brake torque	kg-m	180	180
鎖緊裝置 (油壓) Clamping device (Hydraulic)	kg/cm ²	40	40
容許積載荷重 Load Capacity	kg	400	400
容許切削扭力 Permissible Cutting Force	kg-m	170	170
最高轉速 Max. rotation speed	轉盤 Table	rpm	11.1
	馬達 Motor	rpm	2000
伺服馬達 (選配) Servo motor (optional)	發那科 FANUC		α12
	三菱 MITSUBISHI		HF-204S
總齒數比 Gear ratio		1/180	1/180
淨重 (不含工作台) Net weight (without pallets)	kg	635	600
淨重 Net weight	kg	820	960

※ 本類產品因規格多樣，無法悉數列出，可依客戶需求客製化設計。

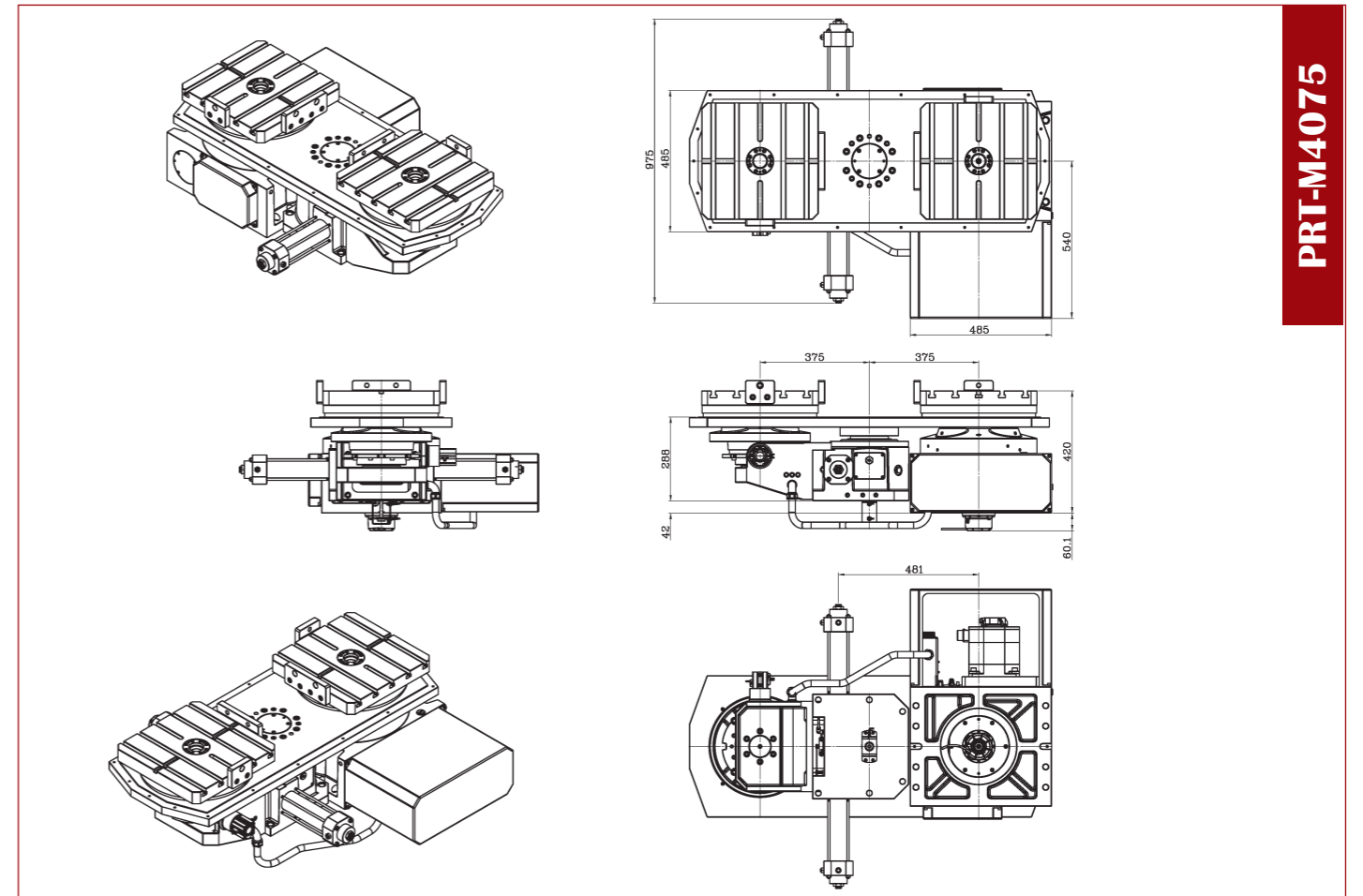

PRT-M4075

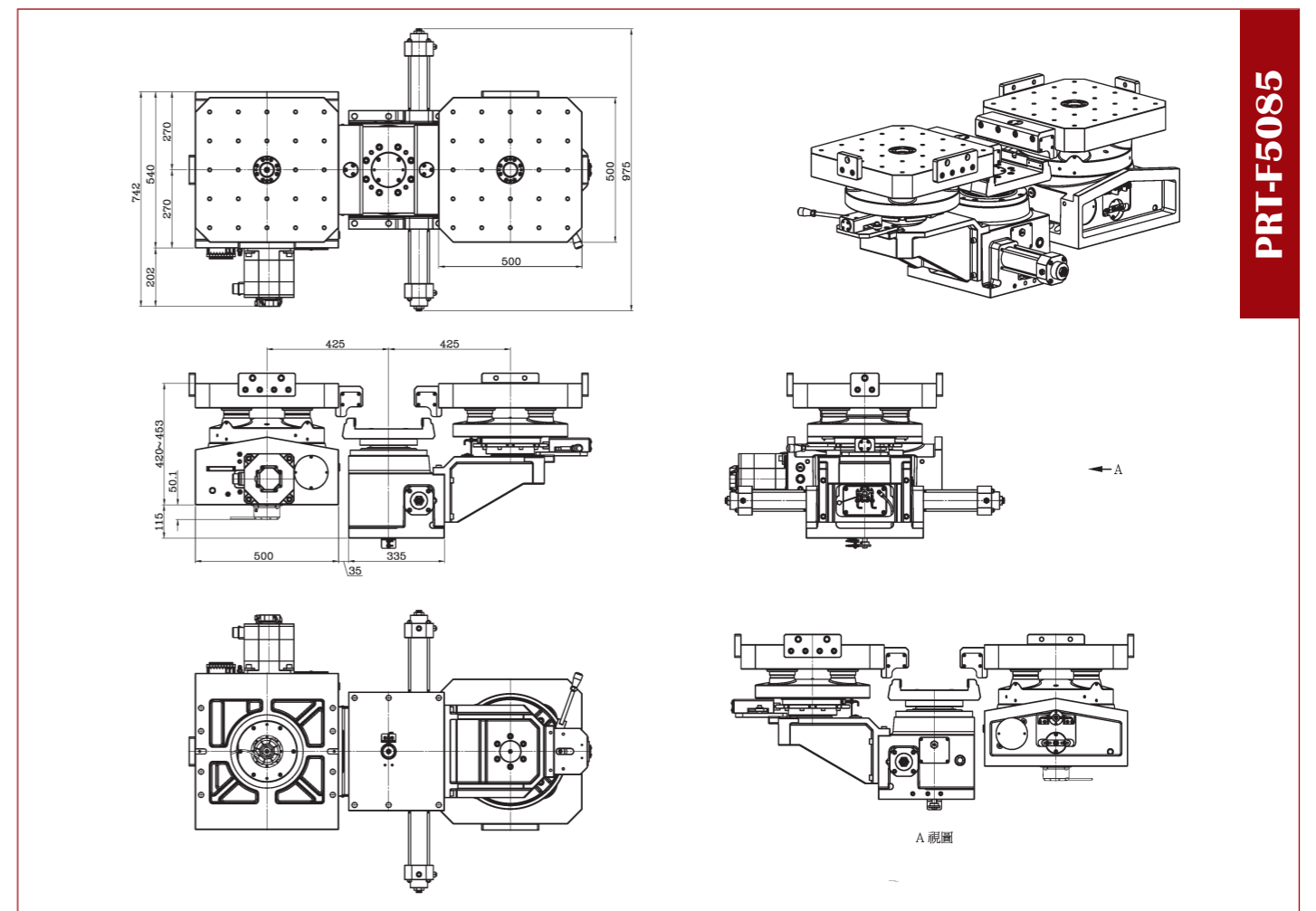

PRT-F5085